



# SERIES LT/4™ PNEUMATIC PRESS

The **PEMSERTER® Series LT/4™** press is designed to install unified or metric self-clinching nuts, studs, and standoffs requiring three tons of insertion force or less.

## Specifications

Ram Force	26.7 kN / 6,000 lbs.
Control System	Pneumatic Logic
Pressure System Type	Pneumatic / Wedge
Air Requirements*	6 to 7 BAR / 90 to 100 PSI
Throat Depth	25.4 cm / 10"
Height	71.1 cm / 28" On Stand - 139.7 cm / 55"
Width	Press Base - 20.3 cm / 8"
Weight	Press - 172 kg / 380 lbs. With Stand - 195 kg / 430 lbs.

\*1 psi = 0.07 bar. 1 bar = 14.5 psi.

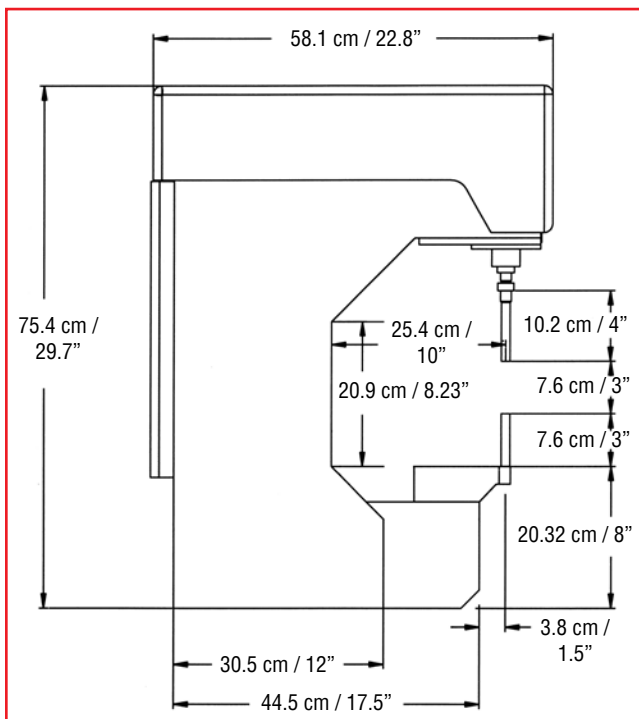

## Features and Benefits

- ▶ Pneumatic power for speed, consistency, and simple operation. Requires shop air only.
- ▶ Integral point-of-operation safety.
- ▶ Adjustable positive ram stop.
- ▶ Rapid tooling changeover, perfect for short production runs.
- ▶ 25.4 cm / 10" throat depth.
- ▶ Large parts tray with dividers.
- ▶ One-year parts warranty and two-year limited warranty on pneumatic components.

## QX4™ MANUAL TURRET TOOL SYSTEM

The PEMSERTER® QX4™ Turret Tool System provides an efficient method to quickly change between four different anvil tools. The one-handed operation of this tool allows an operator to install four different types and/or sizes of fasteners with one set-up. The QX4 Turret Tool System can be easily installed on all new and existing PEMSERTER® Series LT/4® presses.

- Lower installed cost. Four different fasteners installed with one machine set-up.
- Increased productivity. Set-up time reduced. Turret is easily rotated by hand and positively locks in place.
- Reduced WIP inventory. No need to stage product for additional hardware requirements.
- Reduced capital equipment cost. No need for multiple machines in a work cell production.
- Uses existing tools. 4 positions accept standard PEMSERTER 3" anvils.
- Reduced risk of missing a fastener or damaging work-piece. Each position is color-coded with matching color coded parts trays.
- Works with press safety systems. Just set-up for one of the fasteners and the installation stroke will do the rest.
- Set installation force to the highest force needed of the four installations for most applications. Consult factory for applications that require vastly different installation forces.
- Star turret design for fastener-type installations that are more difficult to access.
- Turret easily rotated by hand.
- Turret easily removed and reinstalled with no realignment needed.



*Specifications subject to change without notice.  
Check our website for the most current version of this bulletin.*

© 2008, PennEngineering

**PennEngineering®**



**North America:** Danboro, PA 18916 USA • E-mail: [pemsertter@pemnet.com](mailto:pemsertter@pemnet.com) • Tel: +1-215-766-8853 • Fax: +1-215-766-3634 • 800-523-5321 (USA Only)  
**U.K. And Europe:** Doncaster, England • E-mail: [uk@pemnet.com](mailto:uk@pemnet.com) Tel: +44 (0)1302 765700 • Fax: +44 (0)1302 367580  
**Asia/Pacific:** Singapore • E-mail: [singapore@pemnet.com](mailto:singapore@pemnet.com) • Tel: +65-6-745-0660 • Fax: +65-6-745-2400  
Shanghai, China • E-mail: [china@pemnet.com](mailto:china@pemnet.com) • Tel: +86-21-5868-3688 • Fax: +86-21-5868-3988

Visit our PEMNET™ Resource Center at [www.pemnet.com](http://www.pemnet.com)